

FLIGHT VEHICLE DESIGN AND INSTRUMENTATION LAB

LAB MANUAL

III B. Tech II Semester

(2017-2018)

Prepared By

Ms. L.SUSHMA (Assoc.Prof) & Ms. D.SMITHA (Assoc.Prof)

Department of Aeronautical Engineering



**MALLA REDDY COLLEGE OF ENGINEERING &
TECHNOLOGY**

(Autonomous Institution – UGC, Govt. of India)

Affiliated to JNTU, Hyderabad, Approved by AICTE - Accredited by NBA & NAAC – 'A' Grade - ISO 9001:2015
Certified)

Maisammaguda, Dhulapally (Post Via. Kompally), Secunderabad – 500100, Telangana State, India

MRCET VISION

To become a model institution in the fields of Engineering, Technology and Management.

To have a perfect synchronization of the ideologies of MRCET with challenging demands of International Pioneering Organizations.

MRCET MISSION

To establish a pedestal for the integral innovation, team spirit, originality and competence in the students, expose them to face the global challenges and become pioneers of Indian vision of modern society.

MRCET QUALITY POLICY.

To pursue continual improvement of teaching learning process of Undergraduate and Post Graduate programs in Engineering & Management vigorously.

To provide state of art infrastructure and expertise to impart the quality education.

PROGRAM OUTCOMES (PO's)

Engineering Graduates will be able to:

1. **Engineering knowledge:** Apply the knowledge of mathematics, science, engineering fundamentals, and an engineering specialization to the solution of complex engineering problems.
2. **Problem analysis:** Identify, formulate, review research literature, and analyze complex engineering problems reaching substantiated conclusions using first principles of mathematics, natural sciences, and engineering sciences.
3. **Design / development of solutions:** Design solutions for complex engineering problems and design system components or processes that meet the specified needs with appropriate consideration for the public health and safety, and the cultural, societal, and environmental considerations.
4. **Conduct investigations of complex problems:** Use research-based knowledge and research methods including design of experiments, analysis and interpretation of data, and synthesis of the information to provide valid conclusions.
5. **Modern tool usage:** Create, select, and apply appropriate techniques, resources, and modern engineering and IT tools including prediction and modeling to complex engineering activities with an understanding of the limitations.
6. **The engineer and society:** Apply reasoning informed by the contextual knowledge to assess societal, health, safety, legal and cultural issues and the consequent responsibilities relevant to the professional engineering practice.
7. **Environment and sustainability:** Understand the impact of the professional engineering solutions in societal and environmental contexts, and demonstrate the knowledge of, and need for sustainable development.
8. **Ethics:** Apply ethical principles and commit to professional ethics and responsibilities and norms of the engineering practice.
9. **Individual and team work:** Function effectively as an individual, and as a member or leader in diverse teams, and in multidisciplinary settings.
10. **Communication:** Communicate effectively on complex engineering activities with the engineering community and with society at large, such as, being able to comprehend and write effective reports and design documentation, make effective presentations, and give and receive clear instructions.
11. **Project management and finance:** Demonstrate knowledge and understanding of the engineering and management principles and apply these to one's own work, as a member and leader in a team, to manage projects and in multi disciplinary environments.
12. **Life- long learning:** Recognize the need for, and have the preparation and ability to engage in independent and life-long learning in the broadest context of technological change.

DEPARTMENT OF AERONAUTICAL ENGINEERING

VISION

Department of Aeronautical Engineering aims to be indispensable source in Aeronautical Engineering which has a zeal to provide the value driven platform for the students to acquire knowledge and empower themselves to shoulder higher responsibility in building a strong nation.

MISSION

The primary mission of the department is to promote engineering education and research. To strive consistently to provide quality education, keeping in pace with time and technology. Department passions to integrate the intellectual, spiritual, ethical and social development of the students for shaping them into dynamic engineers

QUALITY POLICY STATEMENT

Impart up-to-date knowledge to the students in Aeronautical area to make them quality engineers. Make the students experience the applications on quality equipment and tools. Provide systems, resources and training opportunities to achieve continuous improvement. Maintain global standards in education, training and services.

PROGRAM EDUCATIONAL OBJECTIVES – Aeronautical Engineering

1. **PEO1 (PROFESSIONALISM & CITIZENSHIP):** To create and sustain a community of learning in which students acquire knowledge and learn to apply it professionally with due consideration for ethical, ecological and economic issues.
2. **PEO2 (TECHNICAL ACCOMPLISHMENTS):** To provide knowledge based services to satisfy the needs of society and the industry by providing hands on experience in various technologies in core field.
3. **PEO3 (INVENTION, INNOVATION AND CREATIVITY):** To make the students to design, experiment, analyze, and interpret in the core field with the help of other multi disciplinary concepts wherever applicable.
4. **PEO4 (PROFESSIONAL DEVELOPMENT):** To educate the students to disseminate research findings with good soft skills and become a successful entrepreneur.
5. **PEO5 (HUMAN RESOURCE DEVELOPMENT):** To graduate the students in building national capabilities in technology, education and research

PROGRAM SPECIFIC OUTCOMES – Aeronautical Engineering

1. To mould students to become a professional with all necessary skills, personality and sound knowledge in basic and advance technological areas.
2. To promote understanding of concepts and develop ability in design manufacture and maintenance of aircraft, aerospace vehicles and associated equipment and develop application capability of the concepts sciences to engineering design and processes.
3. Understanding the current scenario in the field of aeronautics and acquire ability to apply knowledge of engineering, science and mathematics to design and conduct experiments in the field of Aeronautical Engineering.
4. To develop leadership skills in our students necessary to shape the social, intellectual, business and technical worlds.

III Year B. Tech, ANE-II Semester

(R15A2184) FLIGHT VEHICLE DESIGN AND INSTRUMENTATION LAB

LIST OF EXPERIMENTS:-

The student is expected to conduct 10 exercises

1. Aircraft Conceptual 3D sketching
2. Creating Airfoil and sketching
3. Estimating Wing Loading
4. Initial sizing of an Transport Aircraft
5. Weight Estimation of Fighter Aircraft
6. Design of Crew compartment
7. Wing Design and Drag Estimation
8. Engine Sizing
9. Cost Estimation
10. Horizontal and Vertical Tail Design

Software Required: Microsoft Excel or C Programming

REFERENCES:

1. AIRCRAFT DESIGN: A Conceptual Approach AIAA Book ISBN:0-930403-51-7 by Daniel P Raymer

INDEX

S.NO	EXP NO	NAME OF THE EXPERIMENT	PAGE NO
1	Intro	Introduction	8
2	1	Aircraft Conceptual 3D sketching and Modeling	14
3	2	Creating Airfoil and sketching	16
4	3	Estimation Wing Loading	20
5	4	Initial sizing of a Transport Aircraft	24
6	5	Weight Estimation of Fighter Aircraft	30
7	6	Design of Crew compartment	33
8	7	Wing design and Determination of CL & CD	35
9	8	Engine sizing	39
10	9	Cost Estimation	41
11	10	Design of Horizontal Tail and vertical Tail	45
12	11	Operation of Hydraulic Test Rig	47
13	12	Operation of Pneumatic Test Rig	50
14	13a	Demonstration of Landing Gear	54
15	13b	Demonstration of Elevator, rudder, flap on actual aircraft	55

INTRODUCTION

Aircraft design is both arts and science and is a separate discipline of aeronautical engineering different from the analytical discipline such as aerodynamics, structure, control and propulsion. It is the intellectual engineering process of creating on paper a flying machine to

1) Meet certain specification

2) Certain pioneer innovative, new ideas and technology

Aircraft design is by its nature an iterative process. This means that estimates and assumptions have sometimes to be made with inadequate data. Such 'guesstimates' must be checked when more accurate data on the aircraft is available.

Requirements are set by prior design trade studies. Concepts are developed to meet requirement, design analysis frequently points towards new concepts and technologies, which can initiate a whole new design effort. All of these activities are equally important in producing a good aircraft concept.

The start of the design process requires the recognition of a 'need'. This normally comes from a 'project brief' or a 'request for proposals (RFP).

PURPOSE AND SCOPE OF AIRCRAFT DESIGN

An airplane is designed to meet the functional and safety requirements. The actual process of design is a task involving

- a) Selection of airplane type and data
- b) Determination of the geometric parameter
- c) Selection of power plant
- d) Structural design and the analysis of various component
- e) Determination of airplane flight and operational characteristics

Designing a new airplane starts from development of a concept - a general idea for airplane.

The design of any aircraft starts out in three phases

1. CONCEPTUAL DESIGN

- The first design step, involves sketching a variety of possible aircraft configurations that meet the required design specifications. By drawing a set of configurations, designers seek to reach the design configuration that satisfactorily meets all requirements as well as go hand in hand with factors such as aerodynamics, propulsion, flight performance, structural and control systems. This is called design optimization.
- Fundamental aspects such as fuselage shape, wing configuration and location, engine size and type are all determined at this stage. Constraints to design like those mentioned above are all taken into account at this stage as well.
- The final product is a conceptual layout of the aircraft configuration on paper or computer screen, to be reviewed by engineers and other designers.

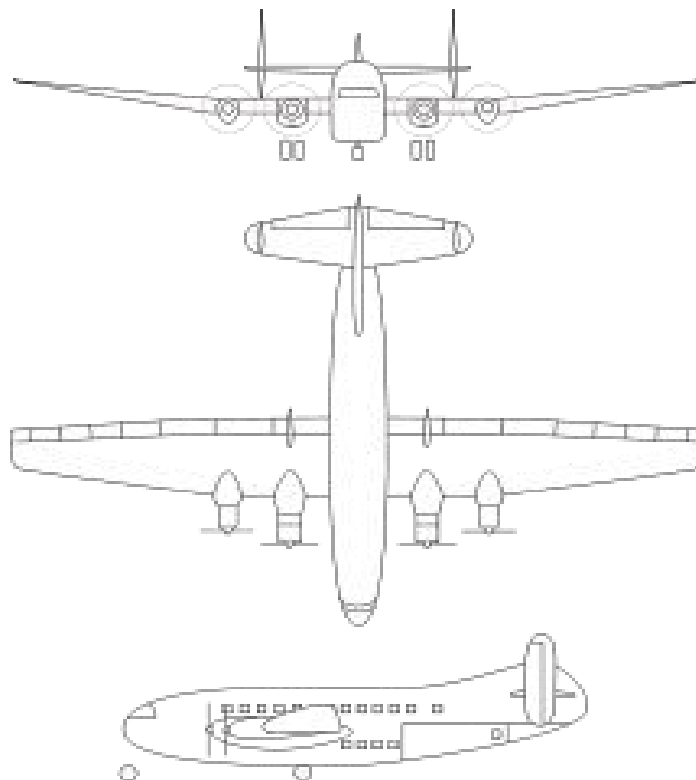

FIG 1: 3D Sketching

1. PRELIMINARY DESIGN PHASE

- The design configuration arrived at in the conceptual design phase is then tweaked and remodeled to fit into the design parameters.
- In this phase, wind tunnel testing and computational fluid dynamics calculations of the flow field around the aircraft are done.
- Major structural and control analysis is also carried out in this phase. Aerodynamic flaws and structural instabilities if any are corrected and the final design is drawn and finalized. Then after the finalization of the design lies the key decision with the manufacturer or individual designing it whether to actually go ahead with the production of the aircraft. At this point several designs, though perfectly capable of flight and performance, might have been opted out of production due to their being economically nonviable.

2. DETAIL DESIGN PHASE

- This phase simply deals with the fabrication aspect of the aircraft to be manufactured.
- It determines the number, design and location of ribs, spars sections and other structural elements. All aerodynamic, structural, propulsion, control and performance aspects have already been covered in the preliminary design phase and only the manufacturing remains.
- Flight simulators for aircraft are also developed at this stage.

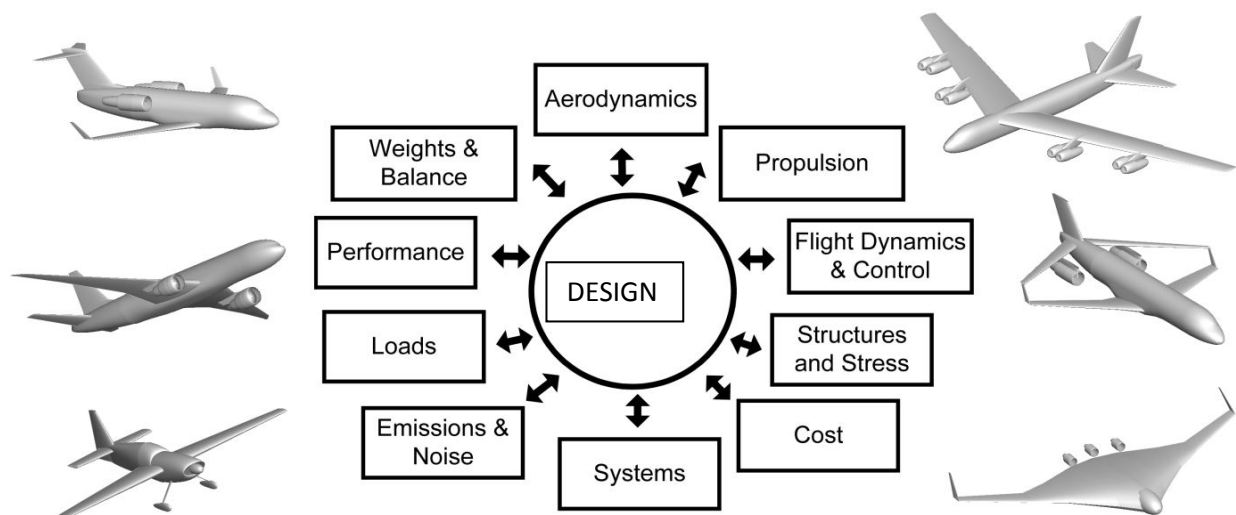

FIG2: Design Cycle

- The concept defines ways; means and parameters that should provide high efficiency and competitiveness of a future airplane, its superiority in comparison with airplanes that are already exploited or designed.
- The concept of a future airplane is determined by requirements for corresponding airplane functional and performance characteristics defined by a customer. Then a concept of a future airplane – its scheme and set of values for main parameters – is chosen.
- All main parameters that will be chosen and determined at these stages should be based on statistics and take into account the aviation development dynamics by forecasting changes of the most important airplane features and characteristics with time. It requires knowledge of the latest achievements in the field of aviation science and technology - aerodynamics, engine, equipment, weapon and airframe engineering, constructional materials, airplane operation and etc.
- Development of the airplane design concept while executing laboratory works, term and graduation design projects requires working up a list of new technical achievements in the field of aviation with estimation of its approximate positive influence on the main airplane parameters and characteristics: possible decrease of airframe mass, fuel and power plant; expected improvement of airplane performance. This list should contain specific technical innovations that should provide the improvement of efficiency ratios for the designed airplane.
- For example, in aerodynamics it can be using new supercritical airfoils, utilizing tip vortex scatterers, wing boundary layer laminarization systems. Constructional perfection can be provided by decreasing the number of structural divisions, applying honeycomb structures, employing new materials such as aluminum, lithium and titanium alloys. While making a detailed list you may approximately estimate the influence of each innovation on corresponding airplane parameters and characteristics. This information can usually be found in dedicated literature, and it is recommended to use it while executing this stage of your project. An example of such estimation of positive influence of state-of-the-art solutions on advanced airplane performance is the fifteen - year scientific and technical forecast made by one of the foreign airplane production companies.

- According to it passenger planes designed and built with 2010th technologies have to weight on 23-35% less then airplanes of the year 1995. This significant take-off mass decrease is achieved by using following technological advances: wing boundary layer laminarization (4-6%), advanced aerodynamic schemes (6%), applying new materials (8–10%), advanced power plants (3%), equipment and systems (1%). These numbers are just an example, and now it can be a little out of date. Fresh forecasts can be found in new publications, especially periodic, combining it with gathering statistics.

ANALYZING THE DESIGN SITUATION

A design situation analysis is carried out on basis of statistics research and airplane development study. During this analysis the following problems should be solved:

1) Future demand for airplanes should be assessed with the required number of airplanes in the certain time, for example, 5-10 years. This information can be found in publication from periodical editions, describing the airplanes of a given type, and in review magazines dedicated to international air shows.

2) History of the development should be investigated, and achieved perfection degree of a given type of airplanes should be mentioned. The average statistical and maximum values of the most important performance parameters, geometric and weight parameters, the mileage rating and cost efficiency of these airplanes should be given. Also maintenance and operating features - airplane cost, traffic handling cost, an airplane life, reliability indexes, comfort ratios and etc. should be included.

3) Development prospects should be studied, and changes in main performance and relative airplane parameters should be forecasted for the near future. Thus, dynamic and static diagrams for the most important prototype parameters should be plotted using data from statistic tables; then their trend functions with an approximation errors should be figured out and forecasted (extrapolated) parameter values should be found

4) New engineering solutions that are expected to improve the value of each parameter should be mentioned.

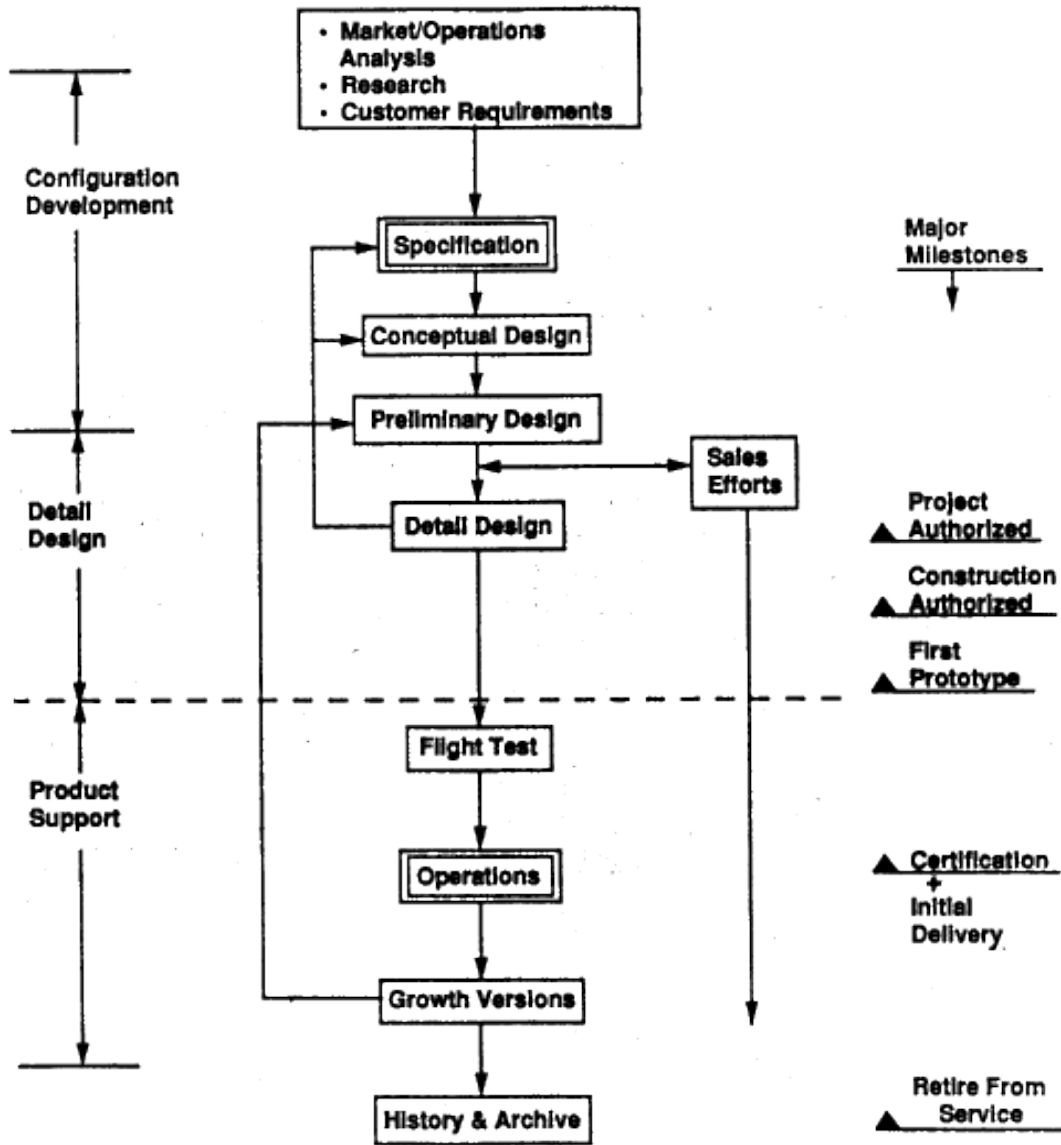

FIG 3: Design Phases

EXPERIMENT 1

AIRCRAFT CONCEPTUAL 3D SKETCHING AND MODELING

Aim: Write the request for proposal for the particular aircraft, Develop the conceptual sketch of the aircraft for given requirements.

Software's used: Catia / Engineering Drawing

Theory:

Conceptual design begins with a specific set of design requirements established from customer or a company-generated guess what future customers may need.

Design requirements include:

- a) Aircraft range
- b) Payload
- c) Take-off distance
- d) Landing distance
- e) Maneuverability and speed requirements

Design begins with innovative idea rather than as a response to a given requirement. Before design a decision is made to what technologies to incorporate, it must use only currently available technologies as well as existing engines and avionics. If designed to build in more distant future, then an estimate technological state of the art must be made to determine which emerging technologies will be ready for use at that time.

Design begins drawing with a conceptual sketch like shown in

Procedure:

1. Write the request for proposal for the given aircraft. It should be in the form of parameters and requirements for the aircraft.
2. Draw the conceptual sketch of the aircraft as explained in theory.
3. Draw the mission profile for the aircraft.

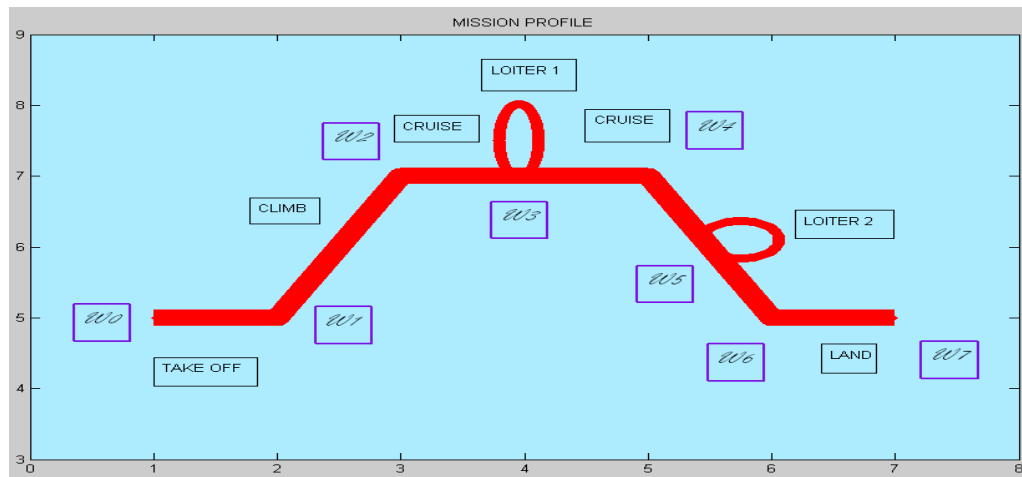

FIG 4: Mission Profile

Validation:

1. Model 3D model of the given aircraft in catia / creo and obtain the 3 views compare with the hand sketch done.

Result:

1. The 3D views of given aircraft configuration by hand sketch and catia are done.

Catia 3D Views

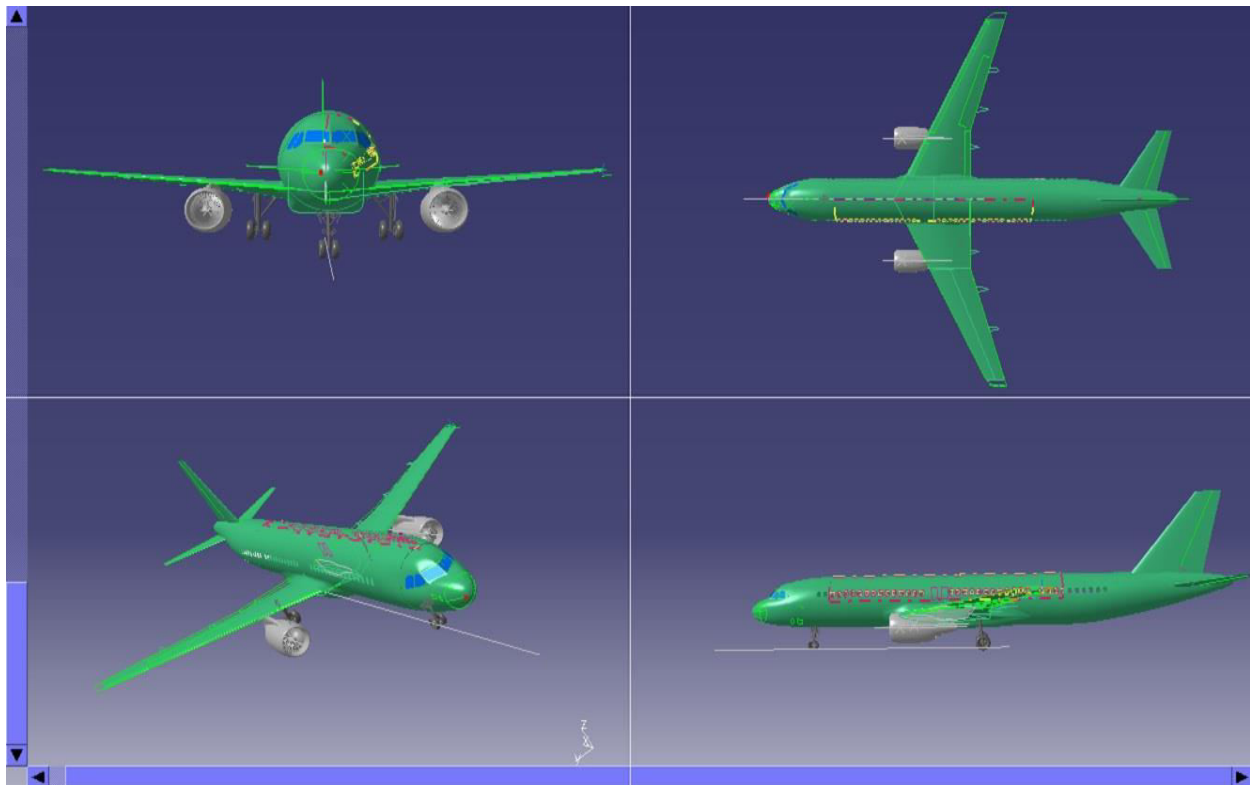

FIG5 : Catia Output of Airbus 3D Modeling

EXPERIMENT 2

CREATING AIRFOIL AND SKETCHING

Aim: To generate airfoil coordinates of a given airfoil series and generate airfoil geometry.

Equipments and methods used:

1. Airfoil sections references
2. Specification chart

Software used: Mat lab

Theory:

Airfoil Nomenclature

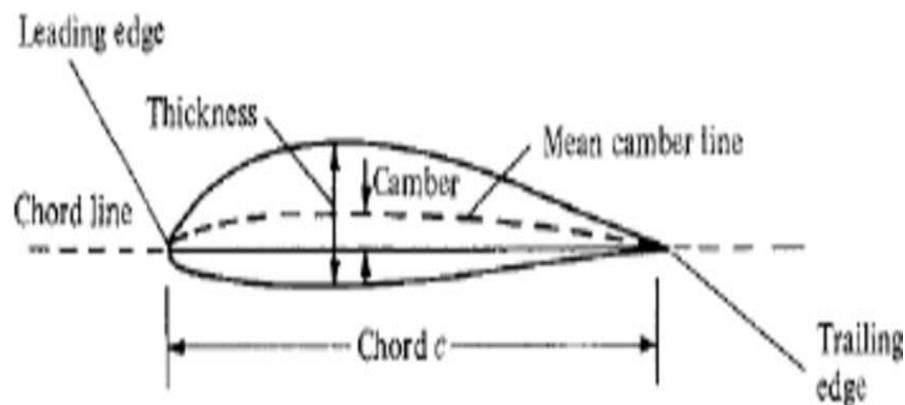

FIG 6 : Airfoil Nomenclature

- **C: chord length** – length from the LE to the TE of a wing cross section that is parallel to the vertical axis of symmetry ·
- **Mean camber line** – line halfway between the upper and lower surfaces –
- **Leading edge (LE)** - is the front most point on the mean camber line.
- **Trailing edge (TE)** - is the most rearward point on mean camber line ·
- **Camber** – maximum distance between the mean camber line and the chord line, measured perpendicular to the chord line
- **Thickness** – distance between upper surface and lower surface measured perpendicular to the mean camber line

Airfoil Nomenclature

2 NACA – National Advisory Committee for Aeronautics - precursor to NASA - National Aeronautics and Space Administration - systematically investigated (and cataloged) effects of various airfoil profile parameters on aerodynamic behavior - developed several series of airfoils and classification systems & many of these airfoils are still commonly used .

4-Digit Series

First number is camber in percentage of chord

second number is location of maximum camber in tenths of chord measured from LE

last two digits give maximum thickness in percentage of chord

5- Digit Series

Designed with location of maximum camber closer to the LE to achieve higher maximum lift coefficients

6- Digit Series

Laminar-flow airfoils - supercritical airfoils and designed to have reduced drag for high subsonic speed. Designed to have drag-divergence Mach number delayed to as close to Mach 1.0 as possible

$$Y_t = \frac{t}{0.2} \left((0.2969 \cdot x^{0.5}) - (0.126x) - (0.3516x^2) + (0.2843x^3) - (0.1036x^4) \right)$$

$$Y_c = \frac{m}{p^2} * (2px - x^2) \quad \text{For } 0 < x < p$$

$$Y_c = \frac{m}{1-p^2} * (1 - 2p - 2px - x^2) \quad \text{For } p < x < 1$$

$$\frac{dY_c}{dx} = \frac{m}{p^2} * (2p - 2x) \quad \text{For } p < x < 1$$

$$\frac{dY_c}{dx} = \frac{m}{1-p^2} * (2p - 2x) \quad \text{For } p < x < 1$$

$$\theta = \arctan \left(\frac{dY_c}{dx} \right)$$

$$x_u = x - (Y_t \cdot \sin\theta)$$

$$x_l = x + (Y_t \cdot \sin\theta)$$

$$y_u = Y_c + (Y_t \cdot \cos\theta)$$

$$y_l = Y_c - (Y_t \cdot \sin\theta)$$

Where **m**= Max camber in % of chord
p= position of max camber in $\left(\frac{1}{10}\right)^{th}$ of chord
t= Max thickness in % of chord

Procedure:

1. Calculate the m, p, t from the given airfoil series
2. Consider a for loop to solve the above equations for the airfoil chord length
3. Calculate $Y_t, Y_c, \frac{dY_c}{dx}, \theta$
4. Calculate x_u, x_l, y_u, y_l
5. Then generate a plot for above to obtain airfoil configuration.

Validation:

1. Generate same airfoil series by using design airfoil and validate with your code generated airfoil.
2. Perform the analytic equations and obtain the results and validate with your code results

Tabulation

x	Yc	Yt	d(Yc)/dx	θ	Xu	Yu	XL	YL

Result: Airfoil has been generated for the given series

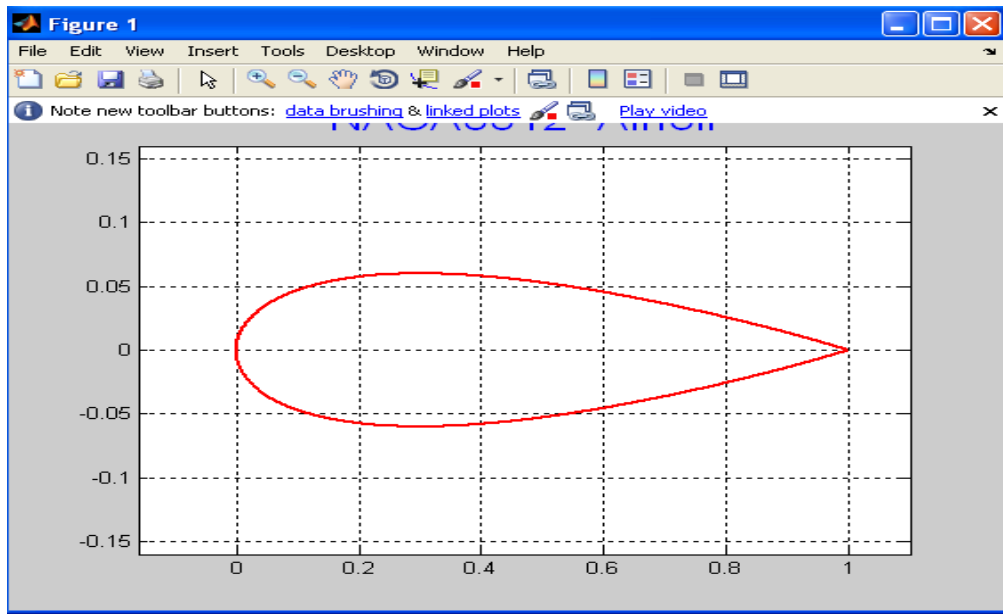

FIG 7: Matlab Result of Aerofoil Generation

EXPERIMENT 3

ESTIMATION OF WING LOADING

Aim: To determine the wing loading of an aircraft for different mission segments

Software used: Mat lab

Theory: Wing loading is the amount of weight that each unit area of the wing must support with lift, measured in (e.g.) pounds per square foot. Airplanes with the higher wing loading land and takeoff at faster speeds and are less maneuverable. Airliners typically have high wing loading, and smaller airplanes have much lower wing loading.

Equations Required:

- Stalling speed , V_{stall} = 117 Knots
- $C_{l\ max}$ for airfoil = 2.7
- Cruise speed , M = 0.9
- Typical cruise speed = 470 Knots
- Allowable landing distance = 2000 fts
- e = 0.85
- AR = 10
- S_a = 1000 fts (airliner aircraft)
- 600 fts (general aviation)

1

STALL CONDITION

FORMULAE :-

W/S	=	$\frac{1}{2} * \rho * (V_{stall})^2 * C_{l\ max}$
$C_{l\ max}$	=	$0.9 * C_{l\ max}$

Since, ρ at sea level = 0.23769×10^{-2} slugs/ft³

CALCULATIONS :

C L max =

W/S = lbs/ft²

TAKEOFF CONDITION

FORMULAE :-

W/S = (TOP) * (σ) * (C L TO) * (T/W)
 C L TO = C l max * (V stall / V TO)²
 V TO = 1.15 * V stall
 T/W = a * (M max)^c

Since, TOP = 450 , at 10,000 ft
 σ = 1 , at sea level
 a = 0.267
 c = 0.363

CLIMB CONDITION

FORMULAE :-

W/S = $\frac{(T/W) + \left((T/W)^2 - \left(\frac{4 \cdot n^2 \cdot C D_o}{\pi \cdot A \cdot e} \right) \right)^{1/2}}{\left(\frac{2 \cdot n^2}{q \cdot \pi \cdot A \cdot e} \right)}$

(T/W)_c = $\frac{1}{(L/D)_c} + \frac{V \text{ vertical}}{V \text{ climb}}$

V vertical = R/C , V climb = 1.2 * V stall

C D_o = $\frac{S \text{ wetted}}{S \text{ ref}} \cdot C \text{ fe}$

q = $(1/2) \cdot (\rho) \cdot (V \text{ climb})^2$, at 1500 ft

Since , n = 1 , ρ = 0.2274×10^{-2} slugs/ft³
 (L/D)_c = 18
 V vertical = 2940 ft/min

4

CRUISE CONDITION

FORMULAE :-

W/S	=	$q * (\pi * A * e * C_{D,o}) / 3$	$^{1/2}$
q	=	$(1/2) * (\rho) * (V_{cruise})^2$	

, at 42,000 ft

Since, $\rho = 0.5337 * 10^{-3}$ slugs/ft³
 $V_{cruise} = 470$ knots

CALCULATIONS :-

q =
W/S = lbs/ft²
5 **LOITER CONDITION**

FORMULAE :-

W/S	=	$q * (\pi * A * e * C_{D,o})$	$^{1/2}$
q	=	$(1/2) * (\rho) * (V)^2$	
V	=	$1.3 * V_{stall}$	

, at 5000 ft

Since, $\rho = 0.1496 * 10^{-2}$ slugs/ft³

CALCULATIONS :-

6

LANDING CONDITION

FORMULAE :-

W/s = $(S_{landing} - S_a) * (\sigma) * (C_{Lmax}) / 80$

Since, $C_{Lmax} = 2.43$
 $S_a = 1000$ fts
 $S_{landing} = 2000$ fts
 $\sigma = 1$

Procedure:

1. Calculate q, V for various segments by using above equations.
2. Calculate W/S stall condition by using the equation = $1/2 * \rho * (V_{stall})^2 * C_{L\ max}$.
3. Calculate W/S takeoff condition by using the equation = $(TOP) * (\sigma) * (C_{LTO}) * (T/W)$
4. Calculate W/S climb condition by using the equation =

$$\frac{(T/W) + \left((T/W)^2 - \left(\frac{4 * n^2 * C_{D,o}}{\pi * A * e} \right) \right)^{1/2}}{\left(\frac{2 * n^2}{q * \pi * A * e} \right)}$$

5. Calculate W/S cruise condition by using the equation = $q * (\pi * A * e * C_{D,o}) / 3)^{1/2}$
6. Calculate W/S loiter condition by using the equation = $q * (\pi * A * e * C_{D,o})^{1/2}$
7. Calculate W/S landing condition by using the equation = $(S_{landing} - S_a) * (\sigma) * (C_{L\ max}) / 80$

Validate:

1. Perform analytical calculations and compare with matlab results

Result: Wing loading of various mission segments are obtained as follows

S. No:	MISSION SEGMENT	(W/S)
1	Stall condition	lbs/ft ²
2	Takeoff condition	lbs/ft ²
3	Climb condition	lbs/ft ²
4	Cruise condition	lbs/ft ²
5	Loiter condition	lbs/ft ²
6	Landing condition	lbs/ft ²

Mat lab result

'S.no'	'MISSION_SEGMENT'	'(W/S)'	'Units'
[1]	'Stall condition'	[112.6162]	'lbs/ft ² '
[2]	'Takeoff condition'	[212.4831]	'lbs/ft ² '
[3]	'Climb condition'	[442.8376]	'lbs/ft ² '
[4]	'Cruise condition'	[67.3742]	'lbs/ft ² '
[5]	'Loiter condition'	[34.1761]	'lbs/ft ² '
[6]	'Landing condition'	[30.3750]	'lbs/ft ² '

EXPERIMENT 4

INITIAL SIZING OF A TRANSPORT AIRCRAFT

Aim: To estimate take-off gross weight for the given aircraft requirements and its mission profile using weight estimation algorithm.

Software used: Mat lab

Theory:

Weight components of airplane explained as follows:

1) Crew weight (W_c)

The crew comprises the people necessary to operate the airplane in flight e.g., Pilot, Co-pilot, Airhostess etc.

2) Payload weight (W_p)

The payload is what the airplane is mentioned to transport passengers, baggage, freight etc. (Military use the payload includes bombs, rockets and other disposable ordnance).

3) Fuel weight (W_f)

This is the weight of the fuel in the fuel tanks. Since fuel is consumed during the course of flight. W_f is a variable, decreasing with time during the flight.

4) Empty weight (W_e)

This is weight of everything else-the structure engines (with all accessory equipment), electronic equipment landing gear, fixed equipment and anything else that is not crew, payload or fuel.

5) Gross weight (W_0)

The sum of these weights is the total weight of the airplane W_0 . Gross weight or total weight W_0 varies through the flight because fuel is being consumed. The design take off gross weight W_0 is the weight of the airplane at the instant it begins its mission. It includes the weight of the fuel.

$$W_0 = W_c + W_p + W_f + W_e$$

$$W_0 = W_c + W_p + \frac{W_f}{W_0} W_0 + \frac{W_e}{W_0} W_0$$

$$W_0 = \frac{(W_c + W_p)}{\left(1 - \frac{W_f}{W_0} - \frac{W_e}{W_0}\right)} \quad (1)$$

Estimation of empty weight fraction (W_e/W_0):

The empty weight fraction (W_e/W_0) can be estimated from data based on

- a) Historical data and tables
- b) Refined sizing data and tables

Estimation of fuel fraction (W_f/W_0):

The aircrafts fuel supply is available for performing the mission. The other fuel includes reserve fuel, trapped fuel (which is the fuel which cannot be pumped out of the tanks).

Fuel fraction (W_f/W_0) is approximately independently of aircraft weight. Fuel fraction will be estimated based on the mission to be flown.

Mission profiles

Typical mission profiles for various types of aircraft are shown in Fig1. The simple cruise mission is used for many transport and general aviation designs, including home built.

Following are the briefly explained the terms that are used in mission profiles:

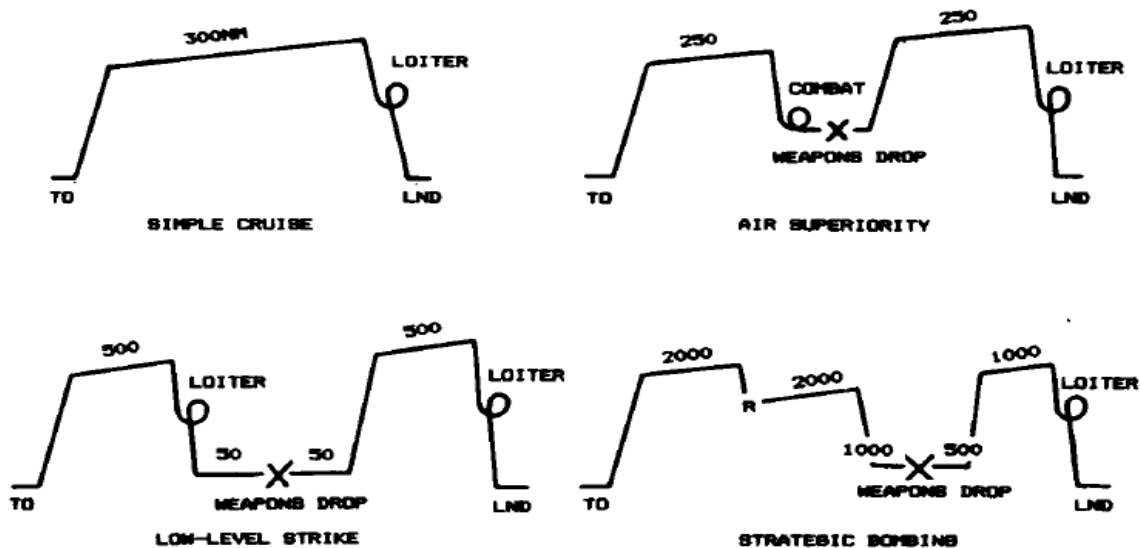

FIG 8: Mission Profiles of Various Aircrafts

- **Warm Up and Take-Off**

Warm Up is the engine start up for the airplane kept idling for some time to warm up. Take Off is the point where aircraft is made lift off from ground. It is the motion after warm up i.e., moving of airplane after starting and till it lifts off from the ground.

- **Climb**

It is between take-off (TO) and cruise (stead level flight with constant speed) Increase in height until airplane achieves steady level flight.

- **Cruise**

It is the steady level flight to cover the mission distance. The mission distance is called Range.

- **Loiter**

Represent the airplane spending in air for some fixed number of minutes near airport before getting the clearance from airport signal or simple spending some time to collect data of some mission (Terrain data).

- **Dash**

It is the mission that must be flown at just a few hundred numbers of feet of the ground for low level strike.

- **Landing**

It is the aircraft landing on the runway till stopping of engine.

Estimation of mission segment weight fractions

The various mission segments (legs) are numbered starting from zero denoting, the start of the mission. Mission leg one is usually engine warm up and take-off. The remaining legs are sequentially numbered. For example in the simple *cruise mission* the legs could be numbered as (0) warm-up and take-off, (1) climb (2) cruise (3) loiter and (4) landing.

Similarly, the aircraft weight at end of each mission is denoted by W_i . Denoting “i”-th segment as mission segment weight

W_0 = Beginning airplane weight (“Take –off gross weight”)

W_1 = Weight of the airplane at end of warm-up and take-off

W_2 = Weight of the airplane at end of climb.

W_3 = Weight of the airplane at end of cruise

W_4 = Weight of the airplane at end of loiter.

W_5 = Weight of the airplane at end of landing.

$$W_x/W_0 = \frac{W_5}{W_0} = \frac{W_1}{W_0} \frac{W_2}{W_1} \frac{W_3}{W_2} \frac{W_4}{W_3} \dots \frac{W_5}{W_4}$$

So in general it can be written as

$$W_x/W_0 = \frac{W_i}{W_0} = \frac{W_1}{W_0} \frac{W_2}{W_1} \frac{W_3}{W_2} \frac{W_4}{W_3} \dots \frac{W_i}{W_{i-1}}$$

Table 1 Empty weight fraction vs W_0

$W_e/W_0 = A W_0^C K_{vs}$	A	C
Sailplane—unpowered	0.86	-0.05
Sailplane—powered	0.91	-0.05
Homebuilt—metal/wood	1.19	-0.09
Homebuilt—composite	0.99	-0.09
General aviation—single engine	2.36	-0.18
General aviation—twin engine	1.51	-0.10
Agricultural aircraft	0.74	-0.03
Twin turboprop	0.96	-0.05
Flying boat	1.09	-0.05
Jet trainer	1.59	-0.10
Jet fighter	2.34	-0.13
Military cargo/bomber	0.93	-0.07
Jet transport	1.02	-0.06

K_{vs} = variable sweep constant = 1.04 if variable sweep
 = 1.00 if fixed sweep

Given warm-up/take-off, climb and landing weight fractions from historical trends: The warm-up, take-off and landing weight fractions can be estimated historically from Table2.

Table 2 Historical mission segment weight fractions

	(W_i/W_{i-1})
Warmup and takeoff	0.970
Climb	0.985
Landing	0.995

Requirements

Aircraft type, engine type, wing sweep type, mission profile, crew weight, payload weight, specific fuel consumption, L/D ratio.

Procedure:

Estimation of gross weight, calculated using following steps:

- 1) Calculate the mission weight fraction of individual segment:

Mission weight fractions of following individual segments:

1) **Take-off (W_1/W_0):** This is taken from Table2.

2) **Climb (W_2/W_1):** This is taken from Table2.

3) **Landing (W_5/W_4):** This is taken from Table2.

4) **Cruise:**

Weight fraction for cruise segment is found using Breguet range formula.

$$R = \frac{V}{C} \frac{L}{D} \ln \left(\frac{W_{i-1}}{W_i} \right)$$

$$\frac{W_i}{W_{i-1}} = \exp \left(\frac{-RC}{V(L/D)} \right) \quad \text{Where } R = \text{range, } C = \text{specific fuel consumption}$$

V = velocity, L/D = lift to drag ratio

5) **Loiter**

Weight fraction for loiter segment is found using Endurance formula.

$$E = \frac{L/D}{C} \ln \left(\frac{W_{i-1}}{W_i} \right)$$

$$\frac{W_i}{W_{i-1}} = \exp \left(\frac{-EC}{L/D} \right) \quad \text{Where } E = \text{endurance or loiter time, } C = \text{specific fuel}$$

consumption, V = velocity, L/D = lift to drag ratio

6) **Empty Weight fraction:** The empty weight fraction can be estimated from Table1 based on the aircraft type and wing sweep.

2) Calculate gross weight of the aircraft from following equation which is function of W_0 .

$$W_0 = \frac{(W_c + W_p)}{\left(1 - \frac{W_f}{W_0} - \frac{W_e}{W_0} \right)} \quad (1)$$

W_e/W_0 Is function of W_0 , W_f/W_0 is also a function of W_0 . W_0 Is calculated from equation(1) through process of iteration. W_0 Has to be assumed, then RHS value of equation (1) is calculated which should match the value of assumed, if it doesn't, increment the assume by some value and iterate it. This process is continued till the absolute difference of RHS value and assumed value is the least and that iteration step will be your nearest solution.

This is done using following iteration table.

Iteration. No	Guess weight	Empty weight	Fuel weight	Calculated weight	Difference= guess-cal

3) Plot graph for calculated weight, guess weight versus iteration number from above table results and compare them in a single graph.

Validation:

1. Perform the analytic equations and obtain the results and validate with your code results

Result: The Gross takeoff weight of the given aircraft is _____

Sample Mat lab output

```

'S_no'  'MISSION_SEGMENT'  'VALUE'
      [1] 'Takeoff condition'  [0.9700]
      [2] 'Climb condition'  [0.9850]
      [3] 'Cruise condition' [0.8986]
      [4] 'Loiter condition' [0.9277]
      [5] 'Cruise condition' [0.8986]
      [6] 'Loiter condition' [0.9917]
      [7] 'Landing condition' [0.9950]
      [8] 'FUEL FRACTION'    [0.3113]
      [9] 'WO CALCULATED'   [7.8172e+004]
    
```

EXPERIMENT 5

WEIGHT ESTIMATION OF FIGHTER AIRCRAFT

Aim: Perform rubber engine sizing of a given fighter aircraft requirements

Software used: Mat lab

Theory:

Table 6.1 Empty weight fraction vs W_0 , A , T/W_0 , W_0/S , and M_{max}

	$W_e/W_0 = (a + bW_0^{C1} A^{C2} (T/W_0)^{C3} (W_0/S)^{C4} M_{max}^{C5}) K_{vs}$						
	a	b	$C1$	$C2$	$C3$	$C4$	$C5$
Jet trainer	0	4.28	-0.10	0.10	0.20	-0.24	0.11
Jet fighter	-0.02	2.16	-0.10	0.20	0.04	-0.10	0.08
Military cargo/bomber	0.07	1.71	-0.10	0.10	0.06	-0.10	0.05
Jet transport	0.32	0.66	-0.13	0.30	0.06	-0.05	0.05

K_{vs} = variable sweep constant = 1.04 if variable sweep
= 1.00 if fixed sweep

Given warm-up/take-off, climb and landing weight fractions from historical trends: The warm-up, take-off and landing weight fractions can be estimated historically from Table2.

$$W_1/W_0 = 0.97-0.99$$

Requirements:

Aircraft type, engine type, wing sweep type, mission profile, crew weight, specific fuel consumption, L/D ratio, different range values, different payload weight values.

Procedure:

1. Draw the mission profile as per the given aircraft requirements, and decide the weight fractions in the mission.
2. Calculate the value of takeoff weight from table 1 as per your aircraft requirements
3. Calculate the climb weight fraction by considering the following equation

Subsonic: $W_i/W_{i-1} = 1.0065 - 0.0325M$

Supersonic: $W_i/W_{i-1} = 0.991 - 0.007M - 0.01M^2$

4. Calculate the value for cruise weight segment

$$\text{Jet: } \frac{W_i}{W_{i-1}} = \exp \frac{-RC}{V(L/D)}$$

5. Calculate the loiter weight fraction by using

$$\text{Jet: } \frac{W_i}{W_{i-1}} = \exp \frac{-EC}{L/D}$$

6. Calculate the combat weight fraction

$$W_i/W_{i-1} = 1 - C(T/W)(d)$$

7. Calculate the Descent weight segment

$$W_i/W_{i-1} = 0.990 \text{ to } 0.995$$

8. Calculate the Landing weight segment

$$W_i/W_{i-1} = 0.992 \text{ to } 0.997$$

9. Calculate Fuel weight fraction

$$\frac{W_f}{W_0} = 1.06 \left(1 - \frac{W_x}{W_0} \right)$$

10. Calculate the gross takeoff weight and empty weight fraction

$$W_0 = \frac{W_{\text{crew}} + W_{\text{payload}}}{1 - (W_f/W_0) - (W_e/W_0)}$$

11. W_e/W_0 is function of W_0 , W_f/W_0 is also a function of W_0 . W_0 is calculated from equation (1) through process of iteration. W_0 Has to be assumed, then RHS value of equation (1) is calculated which should match the value of assumed, if it doesn't, increment the assume by some value and iterate it. This process is continued till the absolute difference of RHS value and assumed value is the least and that iteration step will be your nearest solution.

12. This is done using following iteration table.

Iteration. No	Guess weight	Empty weight fraction	Fuel weight fraction	Calculated weight	Difference= guess-cal

Validation:

2. Perform the analytic equations and obtain the results and validate with your code results

Result: The Gross takeoff weight of the given aircraft is _____

EXPERIMENT 6

DESIGN OF CREW COMPARTMENT

Aim: To design crew compartment with the given requirement.

Software used: Catia/ CREO

Theory:

In conventional aircraft the fuselage serves to accommodate the payload. The wings are used to store fuel and are therefore not available to accommodate the payload. The payload of civil aircraft can consist of passengers, baggage and cargo. A fuselage fineness ratio l_d / F of approximately 6 provides the smallest tube drag¹ Fig. 6.1 also gives the number of seats per row for other fineness ratios. A circular or near-circular cross-section is suitable for a pressure cabin for reasons of strength. If no baggage is to be transported under the cabin floor, the fuselage can be flattened out at the bottom (Fokker 50, for example). The fuselage cross-section can also be composed of two overlapping circular cross-sections.

The certification regulations define minimum requirements for the width and number of aisles. However, the figures in the certification regulations should be seen as minimum safety standards, which are, for example, intended to allow successful emergency evacuation. Today's comfort standards require larger aisle widths and fewer seats at the aisles than prescribed.

Equations used:

1. $nSA = 0.45 \cdot nPAX$.
2. JAR 25.817 says:
3. $nSA \leq 6$: one aisle
4. $6 < n \leq 12$ SA : two aisles
5. $V(VV)VCARGO_COMPARTMENTBAGGAGECARGOOVERHEAD_STOWAGE$

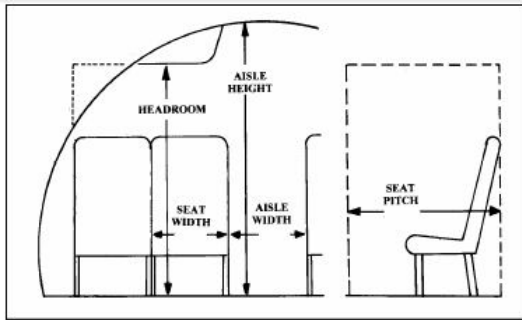

Fig. 6.2:
Definition of key cabin and seat dimensions
[RAYMER 89]

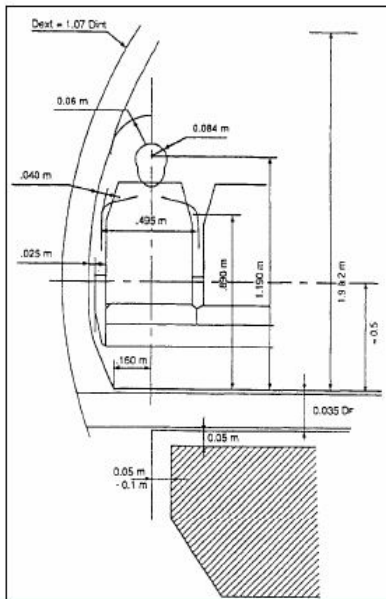

Fig. 6.3:
Some key dimensions for passengers, seats, cabin and cargo compartment.
[SCHMITT 98]

	First class	Economy	High density/ small aircraft
Seat pitch (in.)	38-40	34-36	30-32
Seat width (in.)	20-28	17-22	16-18
Headroom (in.)	> 65	> 65	-
Aisle width (in.)	20-28	18-20	≥ 12
Aisle height (in.)	> 76	> 76	> 60
Passengers per cabin staff (international-domestic)	16-20	31-36	≤ 50
Passengers per lavatory (40" × 40")	10-20	40-60	40-60
Galley volume per passenger (ft ³ /pass)	5-8	1-2	0-1

FIG 7: Cargo Design specifications

Validation: Compare with theoretical calculation

Result: Crew compartment 3D modeling is done.

EXPERIMENT 7

WING DESIGN AND DRAG ESTIMATION

Aim: Design wing according to the given data and plot the graph for α Vs C_L and C_L Vs C_D

Software used: Mat lab

Requirements: Wing area, aspect ratio, drag polar, span efficiency factor.

Theory:

The induced drag coefficient of moderate angle of attack is proportional to square of the lift coefficient with a proportionality factor called the “*drag-due-to-lift-factor or K*”

$$C_D = KC_L^2 \quad (1)$$

Following are the two methods to estimate “drag-due-to-lift-factor or K “:

- 1) **Oswald’s span efficiency method**
- 2) **Leading edge suction method**

1) Oswald’s span efficiency method:

According to classical wing theory, the induced drag coefficient of 3D-Wing with an elliptical lift distribution equals the square of lift coefficient divided by πA (A = Aspect Ratio or Effective Aspect Ratio)

$$K = \frac{1}{\pi A e} \quad (2)$$

A = Aspect Ratio

$A_{effective}$ = Effective Aspect Ratio

e = Oswald’s span efficiency (The value of e varies from 0.7 to 0.85)

Effective Aspect Ratio for

$$\text{End-plates: } A_{effective} = A(1 + 1.9h/b) \quad (3)$$

h = height of Endplate

$$\text{Winglets: } A_{effective} \cong 1.2A \quad (4)$$

Straight wing aircraft:

$$e = 1.78(1 - 0.045A^{0.68}) - 0.64 \quad (5)$$

Swept wing aircraft:

$$e = 4.61(1 - 0.045A^{0.68})(\cos \Lambda_{LE})^{0.15} - 3.1 \quad (6)$$

Supersonic aircraft:

$$e = \frac{A[M^2 - 1]}{4A(\sqrt{M^2 - 1}) - 2} \cos \Lambda_{LE} \tag{7}$$

Λ_{LE} = Sweep angle of leading edge

Disadvantages of Oswald span efficiency method:

- 1) Ignores the variation of K with lift coefficient.
- 2) This doesn't include the effects of the change in viscous separation as lift coefficient is changed.

Wing Details

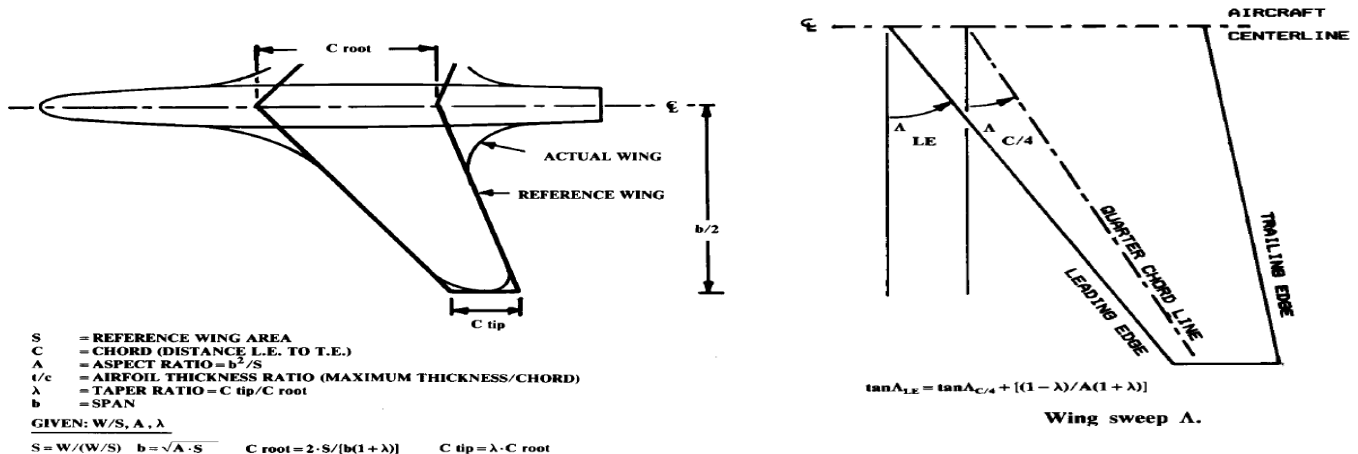

FIG 9a & 9b: Wing Design

2) Leading Edge Suction Method:

This is a semi-empirical for estimation of K allows for the variation of K with lift coefficient and Mach number. Due to the rapid curvature at the leading edge, there creates a pressure drop on the upper part of the leading edge. The reduced pressure exerts a suction force on the leading edge in a forward direction. This "leading edge suction" force S is in the direction perpendicular to the normal force N.

$$K = SK_0 + (1 - S)K_{100} \tag{8}$$

K = drag-due-to-lift-factor

$$K_{100} = \frac{1}{\pi A}$$

$$K_0 = \frac{1}{C_{l\alpha}}$$

$C_{l\alpha}$ = slope of the lift curve, angle taken in radians

S = Leading edge suction factor

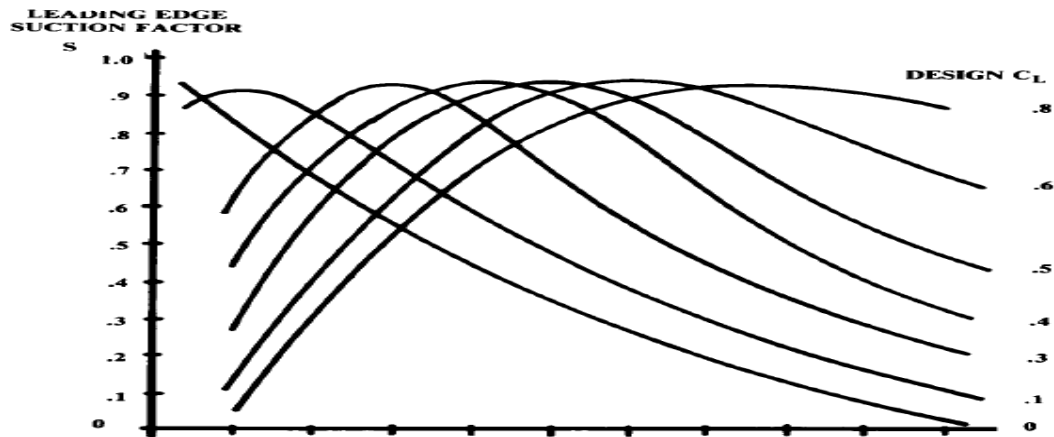

FIG 10: Grapg For Design CL

Equations Used:

* AIRFOIL DATA : 2414

$C_{l\max}$	=	1.5
$C_{l\alpha}$	=	0.11 / 1°
Aerodynamic Centre	=	0.25 C
α_{oL}	=	-1.33
$C_{d,o}$	=	0
r_{LE}	=	0
C_l at minimum drag	=	0.1 - 0.3
t/c max	=	0.15

* DESIGN PARAMETER :

M at Cruise	=	0.9		
S	=	$\frac{W_{\text{cruise}}}{(W/S)_{\text{cruise}}}$	=	fts
W cruise	=	$(W_2+W_3) / 2$	=	lbs
Λ_{LE}	=	25°		
λ	=	0		
C_L start cruise	=	$W_2 / (S * q)$	=	
C_L end cruise	=	$W_3 / (S * q)$	=	

• AIR PROPERTIES :

Cruise Altitude	=	42,000	ft
Velocity at Cruise	=	470	knots

ρ	=	$0.5337 * 10^{-3}$	sl/ft ³
q	=	167.92	
v	=	$0.5564 * 10^{-3}$	ft ² /s
μ	=	$0.2969 * 10^{-6}$	sl/ft/s

Procedure:

1. Calculate K , C_D , C_r , b , Λ t/c , M $efft$, β from the equations mentioned.
2. Calculate C_L $\alpha=0$, $dC_L/d\alpha$, C_L from the given equations.
3. Consider switch case to find area for your prompted wing shape.
4. Consider a for loop to find drag for the given wing chord length by considering it as a flat plate
5. Calculate C_f , S wet, F , $C_{D,o}$
6. Consider for loop for various α values
7. Plot α Vs C_L and C_L Vs C_D .

Tabulation:

α	C_L	C_D	L	D

Result: The variation of C_L and C_D for various angle of attack are obtained

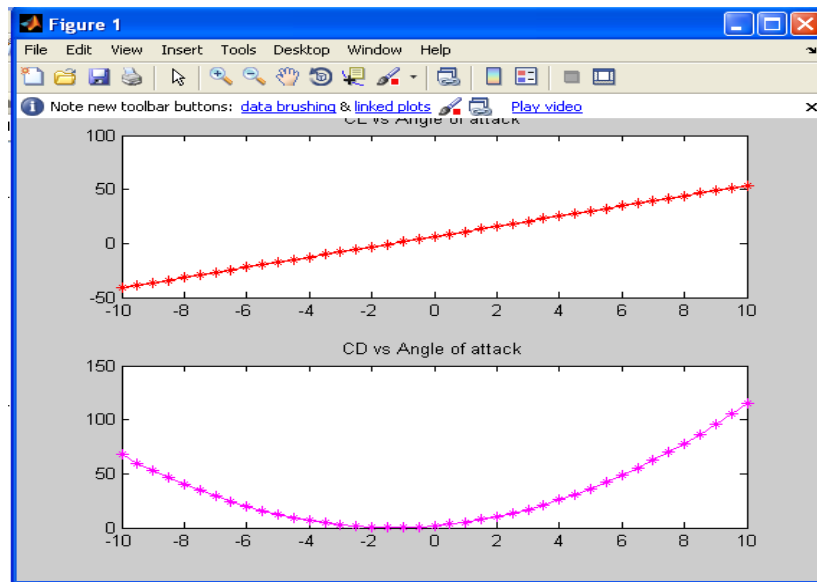

FIG 11: Matlab Result of CL Vs CD

EXPERIMENT 8

ENGINE SIZING

Aim: To estimate the total drags on an aircraft.

Software used: MATLAB

Theory: To develop the propulsion system it is necessary to know the actual dimensions and installation requirements of the engine and as well as its supporting equipment like inlet, nozzle or propellers

Equations used:

Nonafterburning engines:

$$W = 0.084 T^{1.1} e^{(-0.045 \text{ BPR})}$$

$$L = 2.22 T^{0.4} M^{0.2}$$

$$D = 0.393 T^{0.5} e^{(0.04 \text{ BPR})}$$

$$\text{SFC}_{\max T} = 0.67 e^{(-0.12 \text{ BPR})}$$

$$T_{\text{cruise}} = 0.60 T^{0.9} e^{(0.02 \text{ BPR})}$$

$$\text{SFC}_{\text{cruise}} = 0.88 e^{(-0.05 \text{ BPR})}$$

Afterburning engines:

$$W = 0.063 T^{1.1} M^{0.25} e^{(-0.81 \text{ BPR})}$$

$$L = 3.06 T^{0.4} M^{0.2}$$

$$D = 0.288 T^{0.5} e^{(0.04 \text{ BPR})}$$

$$\text{SFC}_{\max T} = 2.1 e^{(-0.12 \text{ BPR})}$$

$$T_{\text{cruise}} = 1.6 T^{0.74} e^{(0.023 \text{ BPR})}$$

$$\text{SFC}_{\text{cruise}} = 1.04 e^{(-0.186 \text{ BPR})}$$

where

W = weight

T = takeoff thrust

BPR = bypass ratio

M = max Mach number

Cruise is at 36,000 ft and $0.9M$.

Procedure:

1. Calculate the weight, thrust, lift and drag from the given equations.
2. Calculate the exit pressure and mach number for the given nozzle configurations

Validation: Check with the theoretical calculations

Result: The engine with given specifications is designed and nozzle exit conditions are calculated

EXPERIMENT 9

COST ESTIMATION

Aim: To estimate the RDT&E cost for 2016 and 2017 as per the given data.

Software used: MATLAB

Theory:

RDT&E and production costs are frequently combined to develop CERs. It is difficult to separate clearly the RDT&E from production cost, especially in the areas of engineering and prototype fabrication for example production of long-lead-time items.

The CER is one of the fundamental techniques used to estimate aircraft cost. A CER is formally defined as a “technique used to estimate a particular cost or price by using an established relationship with an independent variable”

The CER is a mathematical relationship that predicts the dependent variable as a function of the independent variables. This relationship is typically developed using a historical dataset of variables and applying a statistical technique, usually regression, to find the parameter estimates of the independent variables

RDT&E (Research, Development, Test and Evaluation): technology research, design engineering, prototype fabrication, flight and ground testing and evaluations for operational suitability. • RDT&E costs are fixed costs (non-recurring costs).

Elements of life cycle cost

- Flyaway (production) costs: labor and material costs to manufacture the airplane including the airframe, engines and avionics.
- Includes production tooling (jigs, fasteners, molds, etc.), manufacturer’s overhead and administrative expenses.
- Production costs are recurring.

Elements of life cycle cost

- Program cost: the total cost to develop and deploy a new airplane into the inventory (mostly military).
- Some aircraft require special ground facilities for operational deployment.

Elements of life cycle cost

- Operations and maintenance: covers fuel, oil, aircrew costs, maintenance, insurance and depreciation.

- Disposal: getting rid of the airplane after its useful life has ended.

RDT&E and Production Costs (DAPCA IV model) Development and Procurement Costs of Aircraft Model

- is a cost estimation relationship model and it estimates the hours required for RDT&E and production by the engineering, tooling, manufacturing and quality control groups.

- These are multiplied by hourly rates to yield costs.

RDT&E and Production Costs (DAPCA IV model)

- Engineering hours: include airframe design and analysis, test engineering, configuration control and systems engineering.

- Tooling hours: includes preparation for production. Design and fabrication of tools and fixtures, production of molds, programming CAD/CAM tools, development and fabrication of production test apparatus.

They include manufacturing costs, manufacturing labour hours costs, QC costs, Avionics costs, flight test check etc.

RDT&E and Production Costs (DAPCA IV model)

- Manufacturing hours: direct labor to fabricate the aircraft; forming, machining, fastening, subassembly fabrication, final assembly, routing (hydraulic, electric and pneumatic lines) and purchased part installation (engines, avionics, sub-systems, etc.)

- Quality control: includes receiving inspection, production inspection and final inspection.

RDT&E and Production Costs (DAPCA IV model)

- Flight test costs: all costs to demonstrate airworthiness and/or compliance with military standards except for the costs of the flight test airplanes themselves.

- Manufacturing materials: raw materials and purchased hardware and equipment from which the airplane is built (aluminum, composites, electric, hydraulic, pneumatic systems, fasteners, etc.)

Inputs:

Equations used:

DAPCA IV Cost Model (cost in constant 2012 Dollars)

- Engineering hours,
 $He = 4.86 We^{0.777} V^{0.894} Q^{0.163}$

- Tooling hours,
Ht=5.99 We 0.777 V 0.696 Q0.263
- Manufacturing hours,
Hm=7.37 We 0.82 V 0.484 Q0.641
- Quality control hours,
Hq=0.076 Hm (cargo airplanes)
Hq=0.133 Hm (all others)

Development support costs,
CD=91.3 We 0.630 V 1.3 ,

Include fabrication of mockups, subsystem simulators, structural and other test items.

- Flight test costs,
CF=2498 We 0.325 V 0.282

FTA1.21 Q: smaller of production quantity or number to be produced in 5 years, FTA: number of flight test airplanes.

Engine production cost,
CENG=3112(0.043Tmax + 243.25Mmax + 0.969Tturbine inlet - 2228)

Increase by 15-20% for a turbofan engine.

- Manufacturing materials cost,
CM=22.1 We 0.921 V 0.621 Q0.799

RDT&E + production costs
= HeRe+ HtRt+HmRm+HqRq +CD+CF+CM+CengNeng+Cavionics

Recommended fudge factors:

- Aluminum: 1.0,
- Graphite-epoxy: 1.1-1.8,
- Fiberglass: 1.1-1.2,
- Steel: 1.5-2.0,
- Titanium: 2.0.

Average wrap rates (employee salary employee benefits+overhead+administrative costs)

Re = \$ 115 / h,

Rt = \$ 118 / h,

Rm = \$ 108 / h,

Rq = \$ 98 / h.

Avionics costs = 5-25% of flyaway cost or \$4000–8000/lb,

- Investment cost factor = 1.1-1.4 * predicted flyaway cost,
- Initial spares = 10-15% purchase price.

Procedure:

1. Calculate the above costs from the given equations
2. Calculate RDT&E costs
3. Plot the pie chart for 2016 and 2017.

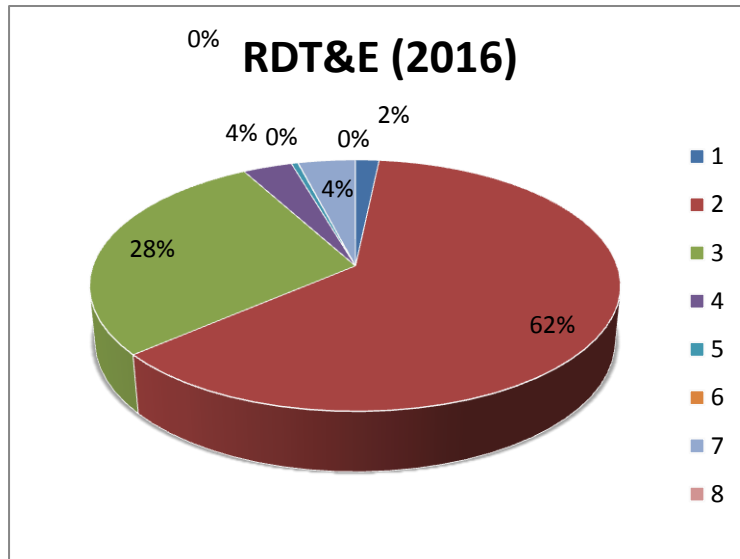

Fig 12: Cost Estimation

Validation:

1. Perform the theoretical calculations and compare with mat lab results

Result: Mat lab code is generated to calculate the RDT&E costs for 2016 and 2017 and are compared with theoretical calculations

EXPERIMENT 10

DESIGN OF HORIZONTAL AND VERTICAL TAILS

Aim: To design horizontal and vertical tails for a jet transport aircraft

Software used: MATLAB

Theory: Tails provide for trim, stability, and control. There are horizontal and vertical tails

Inputs:

1. Wing data: $b = 32.2$ ft ; $mac = 21.5$ ft ; $S = 519$; $M = 0.9$; $\Lambda LE = 62^\circ$; $t/c = 0.04$; $\lambda = 0$.
2. Vertical tail data : $C_{vt} = 0.07$; $L_{vt} = 40$; $\Lambda LE = 63^\circ$; $\lambda = 0.3$; $A_{vt} = 1.1$; $t/c = 0.04$
3. Horizontal tail data: $C_{ht} = 0.11$; $L_{ht} = 50$; $\Lambda LE = 63^\circ$; $\lambda = 0.35$; $A_{ht} = 2$; $t/c = 0.04$

Equations used:

$$b = (A_{vt} * S_{vt})^{(1/2)}$$

$$C_r = \frac{2 * S_{vt}}{b * (1 + \lambda)}$$

$$C_t = \lambda * C_r$$

$$S_{vt} = C_{vt} * \frac{b * w * S_w}{L_{vt}}$$

$$m.a.c = \frac{2 * C_r}{3} \frac{1 + \lambda + (\lambda^2)}{1 + \lambda}$$

$$b = (A_{ht} * S_{ht})^{(1/2)}$$

$$C_r = \frac{2 * S_{ht}}{b * (1 + \lambda)}$$

$$C_t = \lambda * C_r$$

$$S_{ht} = C_{ht} * \frac{(m.a.c)w}{L_{ht}}$$

$$m.a.c = \frac{2 * C_r}{3} \frac{1 + \lambda + (\lambda^2)}{1 + \lambda}$$

3

$1+\lambda$

Procedure:

1. Calculate b , C_r , C_t , S_{ht} , mac for horizontal tail with the given equations.
2. Plot the coordinates to obtain horizontal tail configuration.
3. Calculate b , C_r , C_t , S_{ht} , mac for vertical tail with the given equations.
4. Plot the coordinates to obtain vertical tail configuration.
5. Develop 3D model in Catia

Validation:

1. Develop 3D model in Catia with the given coordinates points.
2. Compare with theoretical calculations and graph
- 3.

Result: Horizontal and vertical tail are generated configurations are generated and 3D modeling is done

Mat lab output

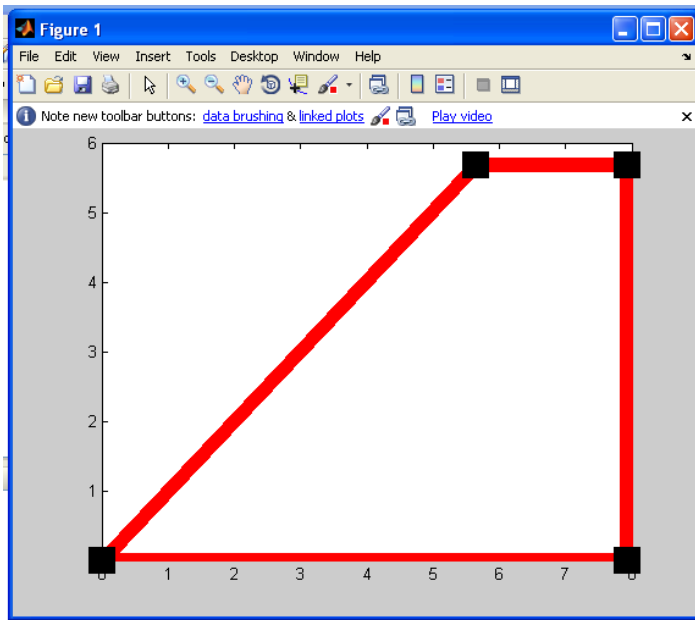

FIG12: Vertical Tail Configuration

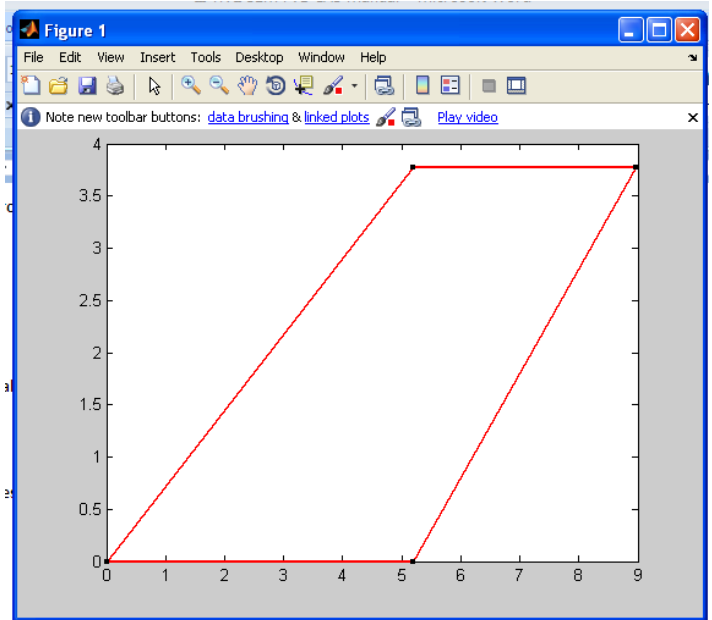

FIG13: Horizontal Tail Configuration

EXPERIMENT 11

OPERATION OF HYDRAULIC TEST RIG

Aim: Operate the hydraulic test rig to deflect the control system.

Equipment Required:

1. Hydraulic test rig

Theory:

A **hydraulic drive system** is a drive or transmission **system** that uses pressurized **hydraulic fluid** to power **hydraulic machinery**. The term hydrostatic refers to the transfer of energy from flow and pressure, not from the kinetic energy of the flow.

Common hydraulic fluids are based on **mineral oil** or water. Examples of equipment that might use hydraulic fluids include excavators and backhoes, hydraulic brakes, power steering systems, transmissions, garbage trucks, aircraft flight control systems, lifts, and industrial machinery.

The Basic Idea

The basic idea behind any hydraulic system is very simple: **Force that is applied at one point is transmitted to another point using an incompressible fluid**. The fluid is almost always an oil of some sort. The force is almost always multiplied in the process. The picture below shows the simplest possible hydraulic system

A **hydraulic pump** is a mechanical source of power that converts mechanical power into **hydraulic energy** (hydrostatic energy i.e. flow, pressure). It generates flow with enough power to overcome pressure induced by the load at the **pump** outlet.

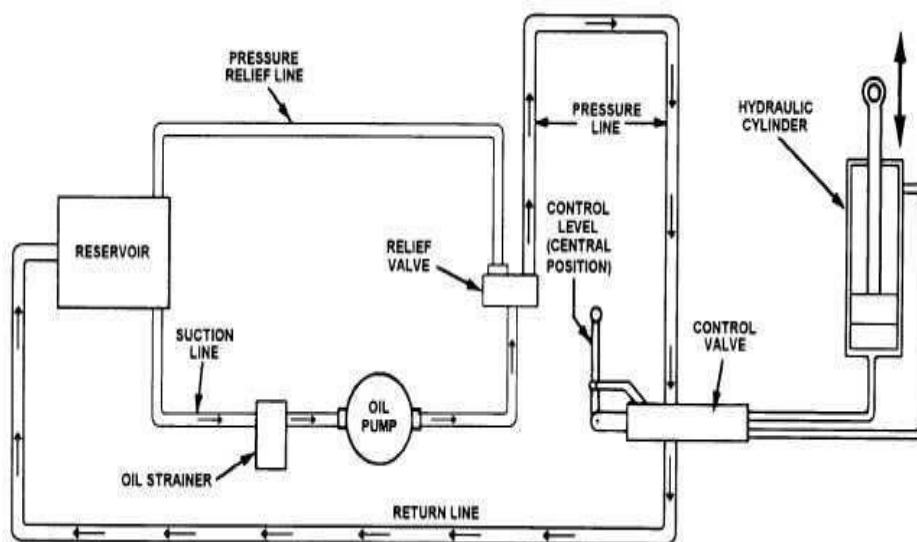
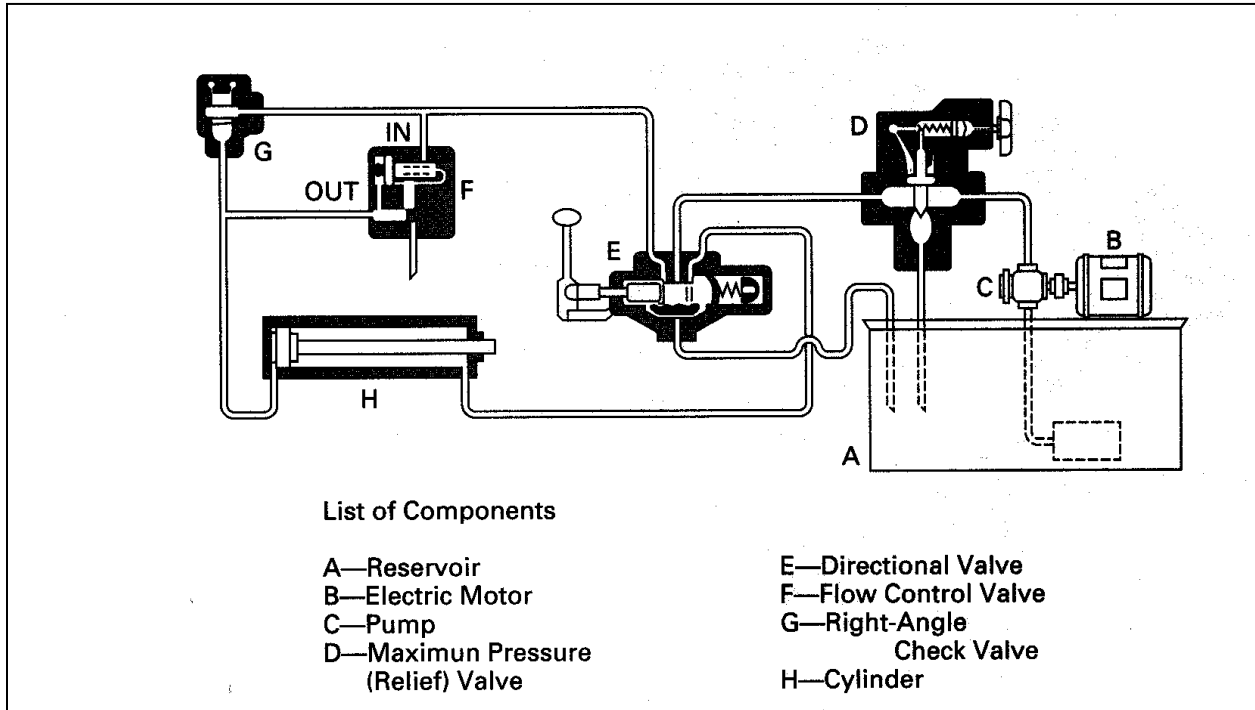
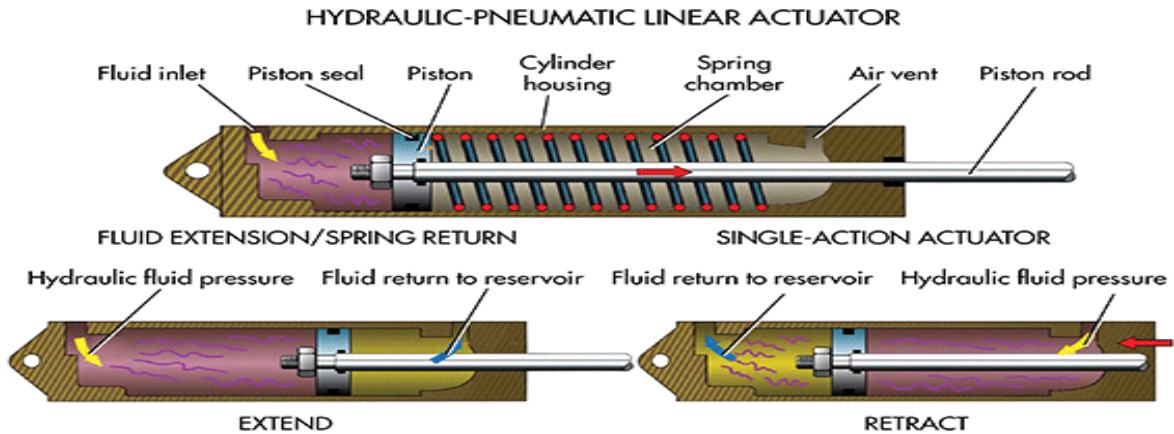

FIG: BASIC HYDRAULIC SYSTEM.



- Pneumatic linear actuators consist of a piston inside a hollow cylinder. Pressure from an external compressor or manual pump moves the piston inside the cylinder. As pressure increases, the cylinder moves along the axis of the piston, creating a linear force. The piston returns to its original position by either a spring-back force or fluid being supplied to the other side of the piston.
- Hydraulic linear actuators operate similarly to pneumatic actuators, but an incompressible liquid from a pump rather than pressurized air moves the cylinder.
- An electric linear actuator converts electrical energy into torque. An electric motor mechanically connected turns a lead screw. A threaded lead or ball nut with corresponding threads that match those of the screw is prevented from rotating with the screw. When the screw rotates, the nut gets driven along the threads. The direction the nut moves depends on which direction the screw rotates and also returns the actuator to its original position.



The top image shows a spring return actuator. The maximum spring compression pushes back on the piston and the hydraulic fluid exits the cylinder and returns to its starting position. The bottom image is a double-acting cylinder where fluid enters either side of the piston depending on the desired motion.

Hydraulic Actuators

Advantages

- Hydraulic actuators are rugged and suited for high-force applications. They can produce forces 25 times greater than pneumatic cylinders of equal size. They also operate in pressures of up to 4,000 psi.
- Hydraulic motors have high horsepower-to-weight ratio by 1 to 2 hp/lb greater than a pneumatic motor.
- A hydraulic actuator can hold force and torque constant without the pump supplying more fluid or pressure due to the incompressibility of fluids
- Hydraulic actuators can have their pumps and motors located a considerable distance away with minimal loss of power.

Disadvantages

- Hydraulics will leak fluid. Like pneumatic actuators, loss of fluid leads to less efficiency. However, hydraulic fluid leaks lead to cleanliness problems and potential damage to surrounding components and areas.
- Hydraulic actuators require many companion parts, including a fluid reservoir, motors, pumps, release valves, and heat exchangers, along with noise-reduction equipment.

Result: The hydraulic test rig is operated

EXPERIMENT 12

OPERATION OF PNEUMATIC TEST RIG

Aim: Operate the pneumatic test rig to deflect the control system.

Equipment Required:

1. Pneumatic test rig

Theory: A pneumatic system is a system that uses compressed air to transmit and control energy.

Pneumatic systems are used in controlling train doors, automatic production lines, mechanical Clamps, etc (Fig).



FIG (a): Automobile production lines



FIG(b): Pneumatic system of an automatic machine

FIG. 1 COMMON PNEUMATIC SYSTEMS USED IN THE INDUSTRIAL SECTOR

(a) THE ADVANTAGES OF PNEUMATIC SYSTEMS

Pneumatic control systems are widely used in our society, especially in the industrial sectors

For the driving of automatic machines. Pneumatic systems have a lot of advantages.

(i) High effectiveness

Many factories have equipped their production lines with compressed air supplies and movable compressors. There is an unlimited supply of air in our atmosphere to produce compressed air. Moreover, the use of compressed air is not restricted by distance, as it can easily be transported through pipes. After use, compressed air can be released directly into the atmosphere without the need of processing.

(ii) High durability and reliability

Pneumatic components are extremely durable and cannot be damaged easily. Compared to Electromotive components, pneumatic components are more durable and reliable.

(iii) Simple design

The designs of pneumatic components are relatively simple. They are thus more suitable for use in simple automatic control systems

(iv) High adaptability to harsh environment

Compared to the elements of other systems, compressed air is less affected by high temperature, dust, corrosion, etc.

v) Safety

Pneumatic systems are safer than electromotive systems because they can work in inflammable environment without causing fire or explosion. Apart from that, overloading in pneumatic system will only lead to sliding or cessation of operation. Unlike electromotive components, pneumatic components do not burn or get overheated when overloaded

(vi) Easy selection of speed and pressure

The speeds of rectilinear and oscillating movement of pneumatic systems are easy to adjust and subject to few limitations. The pressure and the volume of air can easily be adjusted by a pressure regulator.

vii) Environmental friendly

The operation of pneumatic systems do not produce pollutants. The air released is also

processed in special ways. Therefore, pneumatic systems can work in environments that demand high level of cleanliness. One example is the production lines of integrated circuits.

(viii) Economical

As pneumatic components are not expensive, the costs of pneumatic systems are quite low. Moreover, as pneumatic systems are very durable, the cost of repair is significantly lower than that of other systems

(b) LIMITATIONS OF PNEUMATIC SYSTEMS

Although pneumatic systems possess a lot of advantages, they are also subject to many Limitations.

i) Relatively low accuracy

As pneumatic systems are powered by the force provided by compressed air, their operation is subject to the volume of the compressed air. As the volume of air may change when compressed or heated, the supply of air to the system may not be accurate, causing a

decrease in the overall accuracy of the system.

ii) Low loading

As the cylinders of pneumatic components are not very large, a pneumatic system cannot drive loads that are too heavy

(iii) Processing required before use Compressed air must be processed before use to ensure the absence of water vapour or dust Otherwise, the moving parts of the pneumatic components may wear out quickly due to friction

(iv) Uneven moving speed

As air can easily be compressed, the moving speeds of the pistons are relatively uneven.

(v) Noise

Noise will be produced when compressed air is released from the pneumatic components

(c) MAIN PNEUMATIC COMPONENTS

Pneumatic components can be divided into two categories

1. Components that produce and transport compressed air.
2. Components that consume compressed air.

All main pneumatic components can be represented by simple pneumatic symbols. Each symbol shows only the function of the component it represents, but not its structure. Pneumatic symbols can be combined to form pneumatic diagrams. A pneumatic diagram describes the relations between each pneumatic component, that is, the design of the system

2 The production and transportation of compressed air

Examples of components that produce and transport compressed air include compressors and pressure regulating components

(a) Compressor

A compressor can compress air to the required pressures. It can convert the mechanical energy from motors and engines into the potential energy in compressed air (Fig. 2). A single central compressor can supply various pneumatic components with compressed air, which is transported through pipes from the cylinder to the pneumatic components. Compressors can be divided into two classes: reciprocating and rotary



Result: The Pneumatic test rig is operated

EXPERIMENT 13A

DEMONSTRATION OF LANDING GEAR

Aim: Operate the landing gear and to deflect and retract using hydraulic system.

Equipment Required:

1. Landing gear rig
2. Hydraulic system

Landing Gear:

Aircraft landing gear supports the entire weight of an aircraft during landing and ground operations. They are attached to primary structural members of the aircraft. The type of gear depends on the aircraft design and its intended use. Most landing gear have wheels to facilitate operation to and from hard surfaces, such as airport runways. Other gear feature skids for this purpose, such as those found on helicopters, balloon gondolas, and in the tail area of some tail dragger aircraft. Aircraft that operate to and from frozen lakes and snowy areas may be equipped with landing gear that have skis. Aircraft that operate to and from the surface of water have pontoon-type landing gear. Regardless of the type of landing gear utilized, shock absorbing equipment, brakes, retraction mechanisms, controls, warning devices, cowling, fairings, and structural members necessary to attach the gear to the aircraft are considered parts of the landing gear system.

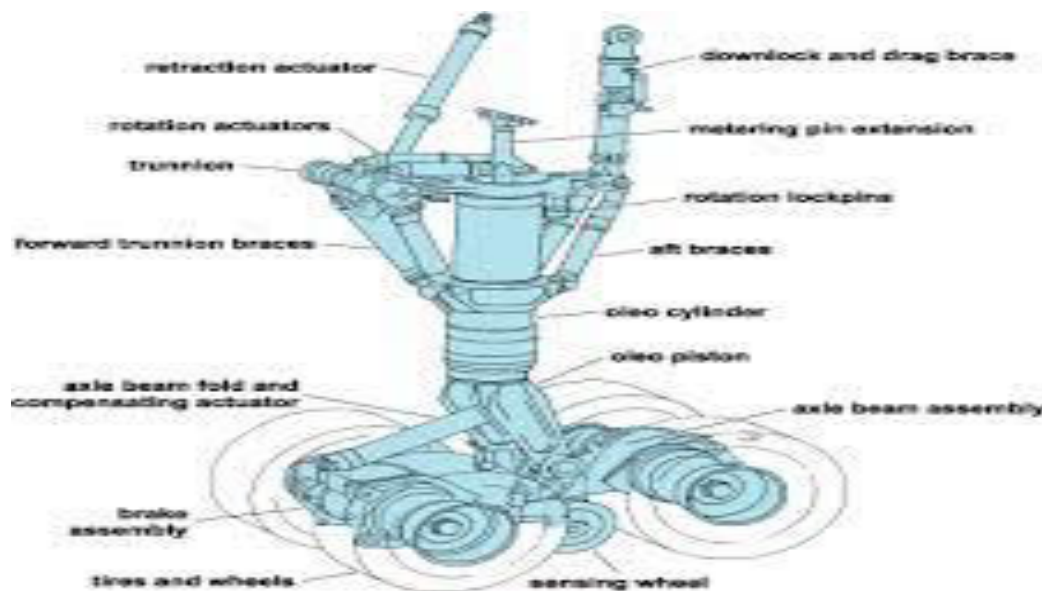

Result: The landing gear test rig is lowered and retracted by using hydraulic pressure of _____.

EXPERIMENT NO 13B

DEMONSTRATION OF ELEVATOR, RUDDER, FLAP ON ACTUAL AIRCRAFT

Aim: Operate the control surfaces and to deflect and retract using hydraulic system.

Equipment Required:

1. Wing assembly
2. Hydraulic system

Ailerons:

Ailerons are mounted on the trailing edge of each wing near the wingtips and move in opposite directions. When the pilot moves the stick left, or turns the wheel counter-clockwise, the left aileron goes up and the right aileron goes down. A raised aileron reduces lift on that wing and a lowered one increases lift, so moving the stick left causes the left wing to drop and the right wing to rise. This causes the aircraft to roll to the left and begin to turn to the left. Centering the stick returns the ailerons to neutral maintaining the bank angle. The aircraft will continue to turn until opposite aileron motion returns the bank angle to zero to fly straight.

Elevator

The elevator is a moveable part of the horizontal stabilizer, hinged to the back of the fixed part of the horizontal tail. The elevators move up and down together. When the pilot pulls the stick backward, the elevators go up. Pushing the stick forward causes the elevators to go down. Raised elevators push down on the tail and cause the nose to pitch up. This makes the wings fly at a higher angle of attack, which generates more lift and more drag. Centering the stick returns the elevators to neutral and stops the change of pitch. Many aircraft use a fully moveable horizontal stabilizer called stabilator or all-moving tail. Some aircraft, such as an MD-80, use a servo tab within the elevator surface to aerodynamically move the main surface into position. The direction of travel of the control tab will thus be in a direction opposite to the main control surface. It is for this reason that an MD-80 tail looks like it has a 'split' elevator system.

In the canard arrangement, the elevators are hinged to the rear of a fore plane and move in the opposite sense, for example when the pilot pulls the stick back the elevators go down to increase the lift at the front and lift the nose up.

Rudder

The rudder is typically mounted on the trailing edge of the vertical stabilizer, part of the empennage. When the pilot pushes the left pedal, the rudder deflects left. Pushing the right pedal causes the rudder to deflect right. Deflecting the rudder right pushes the tail left and causes the nose to yaw to the right. Centering the rudder pedals returns the rudder to neutral and stops the yaw.

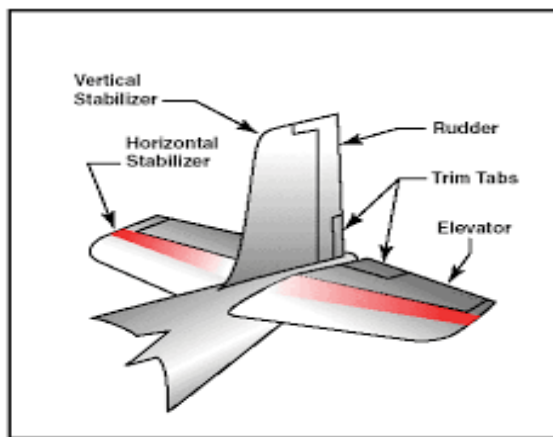

FIG:

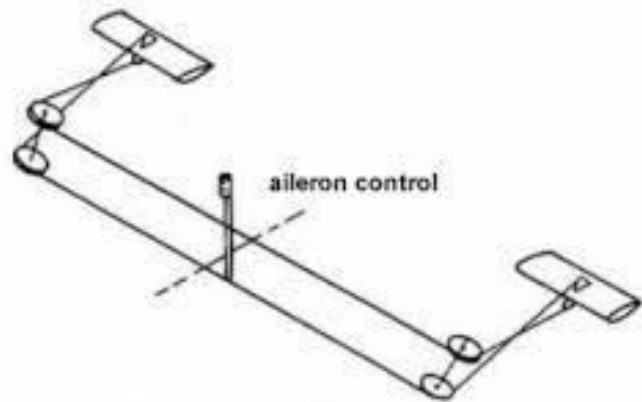

FIG:

Result: The control surface test rig is lowered and retracted by using hydraulic pressure of _____.

VIVA SAMPLE QUESTION

- 1) Explain What is design & design wheel
- 2) Explain about three phases of aircraft design process in detail
- 3) Define aircraft range
- 4) Explain about sizing
- 5) Define take off gross weight
- 6) Write the equation for rubber Engine sizing
- 7) Define airfoil thickness ratio
- 8) Explain chord of the airfoil
- 9) Explain in brief about airfoil geometry with a neat sketch
- 10) Define camber ,aspect ratio, dihedral angle
- 11) Explain about typical airfoil pressure distribution
- 12) Define Reynolds number , dynamic pressure , wing loading
- 13) Explain about geometric twist
- 14) Define thrust to weight ratio
- 15) Brief about instantaneous turn and sustained turn
- 16) Give the equation of endurance of aircraft
- 17) Define pitch of the seats and headroom
- 18) Explain about weapons carriage
- 19) Define profile drag , form drag ,wave drag & interference drag
- 20) Brief Bernoulli's principle
- 21) With a neat sketch explain about lift curve slope Vs mach number
- 22) Define drag polar with a neat sketch
- 23) Define Oswald's span efficiency
- 24) Explain in detail about V- N diagram
- 25) Define level turn , steady level flight
- 26) Brief about down wash and up wash
- 27) With a neat Sketch explain about the various types of nozzles for a jet engine
- 28) Write a short notes on fuel fraction estimation
- 29) Explain mission profiles with a neat sketch
- 30) Give a brief note on how the flow field around a typical airfoil changes its direction and generates circulation.
- 31) What is Sears-Haack volume distribution
- 32) What do you understand by boundary-layer diverter?
- 33) The drag coefficient C_D is generally written as
- 34) The drag polar is commonly written as
- 35) Define service and absolute ceilings.
- 36) What causes induced drag
- 37) Define neutral point
- 38) What are the conditions for maximum endurance of a jet powered airplane?
- 39) What is the criterion for static longitudinal stability?
- 40) Differentiate between yaw and sideslip angle.
- 41) Graphically represent a system which is statistically stable but dynamically unstable

- 42) What is spiral divergence?
- 43) With a sketch explain about the typical mission profile of a transport airplane
- 44) What are the various segments of the mission that can be grouped five categories?
Explain
- 45) Define specific fuel consumption
- 46) How airfoil generates lift
- 47) What is empty weight and payload weight
- 48) Define rubber engine
- 49) Explain with expression for CL_α for the supersonic phase?
- 50) What do you mean by 'Transonic phase' of flight?
- 51) Explain about the various types of valves used in Hydraulic systems
- 52) What are various systems used for actuation of control surfaces, ramp doors etc.
- 53) Discuss about the oleo strut, shimmer devices.
- 54) Explain about various pressure requirements of tires in landing gear
- 55) Explain about return line function